



Laboratory Equipment Manufacturer  
www.mrclab.com



# Operation Manual for Auto Hematology Analyzer HA-17600



**PLEASE READ THIS MANUAL CAREFULLY BEFORE OPERATION**

3, Hagavish st. Israel 58817 Tel: 972 3 5595252, Fax: 972 3 5594529 mrc@mrclab.com

**MRC.VER.01-4.12**

Thank you very much for being the user of **Auto Hematology Analyzer**.

In order to get best test result, before doing clinical test, you shall be familiar with this analyzer and its performance. This user's manual is the using guideline of **Auto Hematology Analyzer**, including installation, daily test, QC and daily maintenance.

**The functions of instruments with difference versions or configurations may be different. The content of user's manual may be different because of upgrade, we will not give notice seperatly.** If you have any question, please contact the distributor.

Please reserve all packing materials for storage, transportation and return to factory for maintenance.

If any problems come into existence, please contact the distributors

**Note** *prompts, advice or suggestion, using italic.*

**Warning** **warnings must be followed strictly to make sure the normal performance of instrument and the accuracy of test result.**

## Declaration

The manufacturer reserves the Power of Interpretation to this user's manual.

The figures in the manual is only for demonstration, they may be different form the actual display, please according to the actual display. Unless been authorised by the manufacturer, No person or orgnization has the right to copy, modify or translate this user's manual.

Only that all the following requirements are met, The manufacturer will be responsible for the safty, reliability and performance of the product.

- Install, adjust, update and repaire are done by The manufacturer authorised person.
- Operation of instrument followed the user's manual strictly.
- Electric environmentmeet the requirements.

## Note

- This instrument shall be operated by prefessional of medical inspection or trained doctor, nurse and experimentalist.

## Warning

- If the orgnization which are using this instrument can not finish a satisfactory maintenance/ repair plan for the instrument, it may cause abnomal fault to the anlyzer even endanger the health of operator.
- The analyzer must be operated under the stated conditions, if not, it may cause abnormal running of instrument, the test results may be not reliable, also it can break the parts of analyzer even endanger the health of operator.

## Main graphical representations used on this instrument



Temperature limitation



Fragile articles

The fragile articles are contained in the transport package, so it should be handled with care when being transported

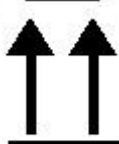

Upwards

It indicates that the transport package shall be kept vertically upward



To be protected from rain

The packaging piece is extensive to the rain



Limit of the number of stacking tiers

It indicates the maximum number of the stacking tiers of the same package. 3 indicate the limit of the stacking tiers.



Biological risks



This means that the labeled item could lead to personal injury and/or damage to the analyzer. The symbol is labeled beside the power outlet and some external interface.

**SN**

Serial number

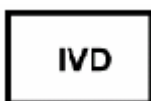

In vitro diagnostic medical device.



Manufacturer

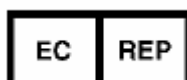

Authorised representative in the european community

## Warnings and security attentions

This instrument is only provided for in vitro diagnosis, please carefully read the following warnings before use. They are required to be strictly followed.

---

**Warning:** please carefully read the following security attentions before use this instrument.

- If the smoke, peculiar smell and sound appears while using, the power supply must be immediately cut off. Meanwhile, the inspection apply shall be immediately presented towards the distributors or agents of The manufacturer. If the instrument continues to be used under this circumstance, the misfire, electric shock or casualties of personnel might be caused.
- The bloods, reagents and metal pieces shall be avoided from entering the interior of this instrument, or the short circuit or misfire with smoke generation will be caused. If abnormality happens, the power supply shall be immediately cut off and the plug of the power supply is extracted from the power socket. Meanwhile, the inspection apply shall be immediately presented towards the distributors and the agents of this company.
- The operator shall not touch the electronic lines in the instrument; especially there will be a danger of electric shock when they are touched by a wet hand.
- The rubber gloves are required to be worn and the prescriptive tools and parts must be used when the instrument is maintained and checked. When the operation ends, please wash your hands using disinfection solutions, or the infection, electric shock or scald might be caused to the part of the skin which contacts with the bloods.
- When the samples are handled, the great care shall be paid and the rubber gloves must be worn, or the infections might be caused. If the samples enter the eyes or wounds, they shall be immediately washed using a large amount of clear water and inspected by the doctor.

#### Usage of reagents

- The reagents shall be avoided from contacting with the skins and clothes when the operation is carried out.
- If the reagents enter the eyes immodestly, they should be immediately washed to be clean using a large amount of clear water and inspected by the doctor.
- If the reagents are wrongly drunk, the help shall be immediately obtained from the doctors and simultaneously a large amount of water shall be drunk so as to vomit the reagents.
- If the hands or skins are touched with the reagents, they shall be immediately washed to be clean using a large amount of clear water.
- The waste products such as used test tubes, other instruments and consumables,

etc shall be appropriately handled as the medical waste products or infectious waste products. If the pollution is caused by bloods, the infection might be generated by pathogens.

- Take proper protection while replacing reagent

#### **Voltage, connection and grounding of power supply**

- The power supply and grounding environment of this instrument are assured to be good and stable.
- The plug of the power supply shall not be inserted into the power socket which is not available for the voltage requirement stated in the backplate of instrument, or the misfire or electric shock might be caused.
- When the instrument is installed, the power supply cable and adapter as accessories attached to the machine must be used and the good grounding shall be assured, or the misfire or electric shock might be caused.
- DO NOT damage the insulation protection skins of the power cord. DO NOT pull the power cord with efforts or hang heavy articles on it, or the short circuit or open circuit might be caused.
- When the peripherals are connected, the power supply must be first cut off, or the short circuit or open circuit might be caused.
- Do not open the side cover or panel while instrument is on, all it may cause damage to some sensitive parts.

**For safety purpose, users are not allowed to refit the instrument.**

---

## Contents

Main graphical representations used on this instrument .....	3
Warnings and security attentions .....	3
<b>1 Instrument Introduction.....</b>	<b>9</b>
1.1 Product introduction .....	9
1.1.1 Product name: Auto Hematology Analyzer .....	9
1.1.2 Test items .....	9
1.2 Product technical parameters .....	9
1.3 Instrument composition and structure .....	9
1.3.1 Front view .....	10
1.3.2 Rear view .....	10
<b>2 Installation .....</b>	<b>12</b>
2.1 Instrument unpacking.....	12
2.2 Installation environment .....	12
2.3 Power requirement .....	12
2.4 Reagent .....	13
2.4.1 Connection of Lyse and cleanser .....	13
2.4.2 Connection of diluent .....	13
2.4.3 Connection of waste .....	13
2.5 Connection of keyboard, mouse .....	13
2.6 Connection of external printer .....	13
<b>3 Sample test .....</b>	<b>14</b>
3.1 Preparation before startup .....	14
3.2 Startup .....	14
3.3 Blood sample collection .....	15
3.3.1 Venous blood collection .....	15
3.3.2 Peripheral blood collection .....	15
3.3.3 Blood sample mixing .....	15
3.4 Blood sample analysis .....	16
3.4.1 Sample data edit .....	16
3.4.2 Blood sample counting .....	17
3.4.3 Parameter prompt message .....	18
3.4.4 Histogram prompt message .....	19
3.4.5 Adjust histogram .....	19
3.4.6 Print .....	20
<b>4 Quality Control.....</b>	<b>21</b>
4.1 L-J QC .....	21

4.1.1 L-J QC setting .....	21
4.1.2 L-J QC run .....	22
4.1.3 L-J QC list .....	22
4.1.4 L-J QC chart.....	23
4.2 X-B QC .....	24
4.2.1 X-B QC setting .....	24
4.2.2 X-B QC list .....	25
4.2.3 X-B QC chart.....	25
4.3 X-R QC .....	26
4.3.1 X-R QC setting.....	26
4.3.2 X-R QC run .....	26
4.3.3 X-R QC list.....	27
4.3.4 X-R QC chart .....	27
<b>5 Calibration .....</b>	<b>29</b>
5.1 Preparation before calibration .....	29
5.2 Manual calibration.....	29
5.3 Auto-calibration .....	30
<b>6 Results.....</b>	<b>33</b>
<b>7 System Setting .....</b>	<b>36</b>
7.1 General setting .....	36
7.2 Other.....	37
7.2.1 User setting.....	37
7.2.2 Normal limits .....	38
7.2.3 Panic limits.....	38
7.2.4 Units.....	39
7.2.5 Communication .....	39
7.2.6 Department information.....	40
7.2.7 Doctor information.....	40
<b>8 System Information.....</b>	<b>42</b>
8.1 System status .....	42
8.2 System log .....	42
8.3 Statistic information.....	42
<b>9 Shutdown.....</b>	<b>44</b>
<b>10 Service .....</b>	<b>45</b>
10.1 Routine maintenance .....	45
10.1.1 Startup and shutdown process.....	45
10.1.2 Automatic rinse .....	45
10.1.3 Clean instrument surface .....	45

10.2 Maintenance program .....	45
10.2.1 Back flush .....	45
10.2.2 Burn .....	45
10.2.3 Drain chambers.....	45
10.2.4 Drain pipeline .....	45
10.2.5 Remove Blockage.....	45
10.2.6 Prime.....	46
10.2.7 Cleaning.....	46
10.2.8 Concentrated cleanser soaking.....	46
10.2.9 Check mechanics.....	46
10.2.10 Debug .....	47
10.2.11 EGINEERING .....	47
10.2.12 Machine reset .....	47
10.2.13 Stop use .....	48
10.2.14 Replace reagent.....	48
11 Troubleshooting .....	49
Appendix Name and concentration of toxic and hazardous substance or element in product .....	50



# 1 Instrument Introduction

## 1.1 Product introduction

### 1.1.1 Product name: Auto Hematology Analyzer

### 1.1.2 Test items

This analyzer is using impedance principle (colorimetry for hemoglobin measurement) to categorize and count blood cells in blood. Test items are shown in Table 1-1.

Table 1-1

Full English name	English abbreviation	Unit(Default)
White blood cell count	WBC	$10^9/L$
Lymphocyte count	LYM#	$10^9/L$
Intermediate cell count	MID#	$10^9/L$
Granulocyte Cell count	GRA#	$10^9/L$
Lymphocyte percentage	LYM%	%
Intermediate cells percentage	MID%	%
Granulocyte Cells percentage	GRA%	%
Red blood cell count	RBC	$10^{12}/L$
Hemoglobin content	HGB	g/L
Hematocrit	HCT	%
Mean corpuscular volume	MCV	fL
Mean corpuscular hemoglobin	MCH	pg
Mean corpuscular hemoglobin concentration	MCHC	g/L
Red cell distribution width SD	RDW-SD	fL
Red cell distribution width CV	RDW-CV	%
Platelet count	PLT	$10^9/L$
Mean platelet volume	MPV	fL
Platelet distribution width	PDW	%
Plateletcrit	PCT	%
Platelet-large cell ratio	P-LCR	%
White blood cell histogram	WBC Histogram	
Red blood cell histogram	RBC Histogram	
Platelet histogram	PLT Histogram	

## 1.2 Product technical parameters

Test principle:	WBC/RBC/PLT: Impedance method; HGB: colorimetry
Aspiration volume:	9.8 $\mu$ L(Whole Blood), 9.8 $\mu$ L(Anticoagulant Peripheral Blood), 20 $\mu$ L(Pre-diluted Peripheral Blood)
Test rate:	About 1 min /ea.
Working environment:	15°C~35°C, relative humidity 10%~90%
Store environment:	0°C~40°C, relative humidity $\leq$ 80%
Power supply:	a.c.110V~220V, 50/60Hz
Input power:	96VA

## 1.3 Instrument composition and structure

The analyzer is composed of chamber, tubing system, computer control system, and software.

### 1.3.1 Front view

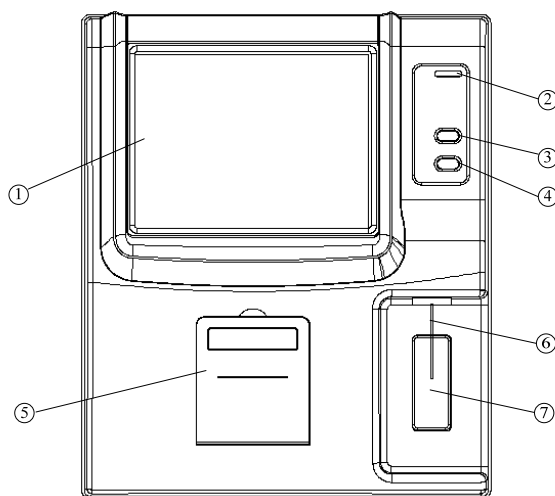

Fig.1-1 Front view

- ① Display screen: Display the software interface
- ② Indicator light: yellow at startup, turn red when starting sample test, turn yellow after test.
- ③ Feed key: built-in printer feeds paper outward
- ④ Aspiration key: in sample analysis, press this key, the instrument will aspirate sample
- ⑤ Printer cover: print paper installing position for built-in printer
- ⑥ Sampling needle: use sampling needle to aspirate sample into chamber
- ⑦ Aspiration key: in sample analysis, press this key, the instrument will aspirate sample, function the same as key ④

### 1.3.2 Rear view

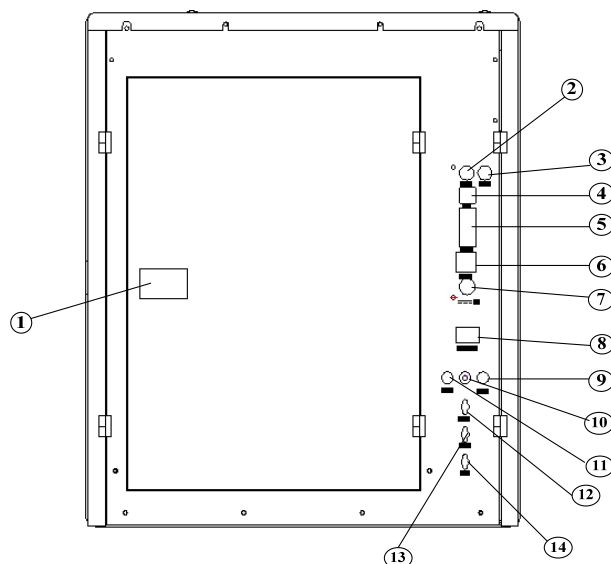

Fig.1-2 Rear view

- (1) Rear cover switch: turn this button, open the rear cover to replace reagent
- (2) Keyboard interface: PS/2 keyboard interface
- (3) Mouse interface: PS/2 mouse interface
- (4) USB port

- (5) RS-232 serial port: to connect with data receiving devices
- (6) Network interface
- (7) Power interface: to connect with external power supply
- (8) Power switch: switch instrument power
- (9) Diluent sensor
- (10) Grounding hole: used for instrument grounding
- (11) Cleanser sensor
- (12) Cleanser port
- (13) Diluent port
- (14) Waste port

## 2 Installation

### 2.1 Instrument unpacking

1. Unpack the instrument's package and remove material for transportation. Please keep original packing carton and packing material, in case you need to repack the instrument in the future.
2. Take out the instrument from plastic package.
3. In accordance with packing list, make sure the packing carton content includes:
  - Hematology analyzer
  - User's manual
  - Packing list
  - Agent warranty certificate
  - Power adapter
  - Product COA

---

**Note:** *Product packing feature is as per packing list, in case of inconformity, please contact seller.*

---

### 2.2 Installation environment

In order to ensure instrument work normally, please choose working place compliant with following condition to place **Auto Hematology Analyzer**:

- No direct sunlight;
- No massive dust or powder;
- No strong electromagnetic radiation;
- Sufficiently large flat and solid desktop.

---

**Note:** *Instrument working environment: temperature 15 °C~35 °C, relative humidity 10%~90%.*

---

### 2.3 Power requirement

- a.c.110V~220V
- 50/60Hz
- 96VA

---

**Warning:** (1) *AC power must be well earthed.*  
(2) *AC power shall be stable, sharing with heavy-duty power appliance is forbidden, rectified power supply is better equipped.*  
(3) *If there is smoke, smell or noise in instrument, immediately shut off power, and contact distributor.*  
(4) *When plugging power line, one must catch the plug itself, instead of power line.*

---

## 2.4 Reagent

The instrument needs to use Lyse, cleanser, diluents for measurement and maintenance. To ensure accuracy of test result, please use reagents accompanied with instrument.

### 2.4.1 Connection of Lyse and cleanser

- 1) From reagent packing carton, take out lyse and cleanser respectively, open the bottle lids, and place them in instrument reagent booth horizontally.
- 2) Insert plastic tube marked Lyse into the Lyse bottle and tighten the bottle cap.
- 3) Insert plastic tube marked cleanser into the cleanser bottle and tighten the bottle cap.

### 2.4.2 Connection of diluent

- 1) Take out diluent catheter from the accessories bag.
- 2) Connect diluent catheter end to "Diluent" route adapter on rear panel of instrument.
- 3) Insert the other end of catheter into diluent bottle, and tighten the bottle cap.

### 2.4.3 Connection of waste

- 1) Take out waste catheter from accessories bag.
- 2) Connect waste catheter end to "Waste" route adapter on rear panel of instrument.
- 3) Clockwise rotate the bottle cap with waste catheter to tighten it on the waste bottle.

---

**Note:**

- (1) Reagent tubing must not be twisted, folded or rotated by force.**
- (2) Please do not use expired reagent.**
- (3) The waste must be treated in accordance with related national regulations, wear rubber gloves when disposing of waste.**

---

## 2.5 Connection of keyboard, mouse

- 1) Carefully take out keyboard and mouse from packing carton.
- 2) Carefully insert keyboard cable plug into socket marked "Keyboard" on instrument rear panel.
- 3) Carefully insert mouse cable plug into socket marked "Mouse" on instrument rear panel.

## 2.6 Connection of external printer

- 1) Make sure both printer and instrument have been shut down.
- 2) Insert one end of USB cable into printer USB interface socket.
- 3) Insert another end of USB cable into instrument USB interface.
- 4) Connect printer and AC power supply with power line accompanied to printer.

## 3 Sample test

### 3.1 Preparation before startup

Before startup, the operator shall check by following steps to make sure system is ready:

1. Check if the diluent, Lyse and cleanser meet the need of current test. Check if the waste bottle is full, tubing system is ok and without folded, all the connection is ok.
2. Whether instrument power adapter is safely and stably connected to power socket.
3. Check whether built-in or external printer paper is sufficiently installed in right position.

### 3.2 Startup

Switch on the , indicator light is on, system begins to check component status, transfer parameter needed by front end, run blank tests, as shown in figure below:



Fig.3-1 Startup program

After startup self-checking, go to sample test screen, as shown below:

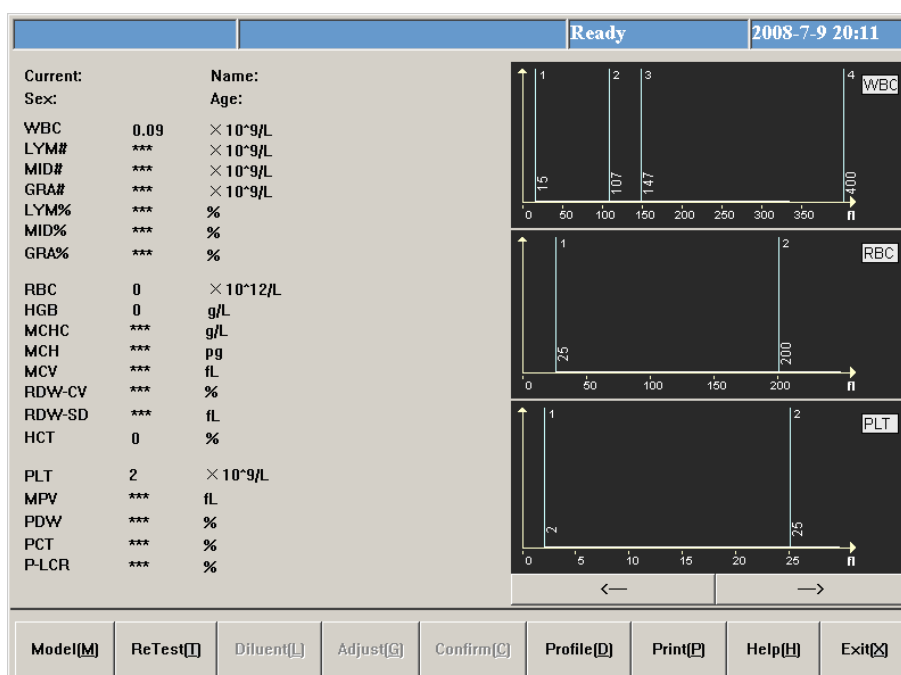

Fig.3-2 Blank test result

Blank test only shows test results of WBC, RBC, HGB, HCT and PLT. The operator can run blank test at any time required. In sample test menu, click "Profile" button, after Data Edit menu pops, change sample no.. to 999, then click "Yes" button, return to sample test menu. Press "Aspiration Key" to start blank test. During test, the indicator light turns red, status column on top of screen will display test status.

Blank test acceptable range is as follows:

Parameter	Reference Range
WBC	$\leq 0.2 \times 10^9 / L$
RBC	$\leq 0.02 \times 10^{12} / L$
HGB	$\leq 1 g / L$
HCT	$\leq 0.5 \%$
PLT	$\leq 10 \times 10^9 / L$

If blank test result exceeds this range, operator has to repeat above test steps until test result is acceptable. If after 5 runs, test result still cannot meet specification, please check reagent and tubing connection, and use "Back Flush" function in "Service" module to eliminate block hole.

After blank test, one can fill out sample no..manually in Data Edit menu, or click "Return" button to return to main screen, go to Sample Test menu again to run sample test.

### 3.3 Blood sample collection

Blood sample collection is classified as venous blood and peripheral blood.

---

**Warning: do not touch blood sample, QC sample and calibration sample directly. Handling of these objects shall comply with related operation instruction.**

---

#### 3.3.1 Venous blood collection

Venous blood can be collected by using vacuum negative pressure tube or ordinary method under atmospheric pressure, anticoagulant must be dropped to all venous blood collection containers in advance, usually EDTA.K<sub>2</sub>.2H<sub>2</sub>O is adopted as anticoagulant, with content of 1.5-2.2mg/ml.

#### 3.3.2 Peripheral blood collection

- Blood sampling position:  
For adults, the inner side of middle finger or ring finger tips of left hand is better; for children above half a year old, middle finger is better; for infant below half a year old, blood is usually sampled from thumb or outer side of foot bottom.
- Blood sampling method:  
It shall be carried out in accordance with peripheral blood collection standard of health authority. Peripheral blood collection normally adopts local centesis; the typical collection method is to pierce through finger end. Blood tube uses 20 $\mu$ L constant volume blood tube or bullet blood tube. It is recommended to collect no less than 30 $\mu$ L blood to facilitate double check.  
During blood sampling, if blood flow stagnates, one may slightly press farther end of wound, never force around piercing hole. Avoid tissue fluid mixed with blood, hampering test analysis result accuracy.

#### 3.3.3 Blood sample mixing

Before test, blood sample must be thoroughly shaken and mixed, the recommended method is: shake up and down, rotate test tube 3-5min, do not shake too violently.

Blood sample to be tested can only stored at room temperature, test shall be done in 4h,

prolonged storage, or inferior mixing will influence test result accuracy.

### 3.4 Blood sample analysis

Prior to sample analysis, it is recommended to take one QC test of instrument, see detail operation in Chapter 4 “Quality Control”.

**Warning: instrument test object is blood sample; suction of other substance may lead to instrument malfunction.**

#### 3.4.1 Sample data edit

In sample analysis, you can modify sample no.. or input sample data before test. Modification after test has to be done in “History Data” module, see detail operation in Chapter 6 “History Data”. Click “Profile” button, Data Edit menu pops out as follows:

Fig.3-3 Sample data entry

- Sample No.: to modify sample no., please input 11-digit number in sample no. box according to format of “year + month+ day +3-digit sequence number”. If this sample No has existed in system, then the user will be asked to use new sample no. Otherwise, the system will cover the existed test results. The system will create sample number for 001 everyday according to the test date.
- Name: maximal 20 letters.
- Sex: male or female may be selected, if no chosen, the system default is blank.
- Age: for Year, Month and Day, just input one number. If multiple items are input, then if year is available, then month and day will not be saved, if month is available, the days will not be saved. Age range is 1-150, month range is 1-30, day range is 1-90.
- Sample type: anti-coagulating whole blood, anti-coagulating peripheral blood and pre-diluted peripheral blood can be chosen.
- Reference: general, male adult, male female, 16-18 years, 6-15 years, 3-5 years, 3 months-2 years, 8 days-2 months, the 1<sup>st</sup> week and user-define value can be selected. The default is general.
- Medical No.: patient medical record no.
- Bed No.: number of sick bed of patient.
- Department, sender, analyst and checker: directly input or select from dropdown box, please see detail setting in Chapter 7 “system setting”.

Click “” to open soft keyboard, as shown below:





Fig.3-4 System soft keyboard

When soft keyboard is used, the cursor has to be moved into input box, then click to input. “Caps” is to toggle between uppercase and lowercase, click “Close” to close soft keyboard. Soft keyboards in other frames are used likely.

Click “OK” button, system will update or save sample data, click “Cancel” button, return to sample test screen.

### 3.4.2 Blood sample counting

You can select blood type by “Mode” button or select form the box at sample data edit menu. There are three kind of blood type for selection, which are whole blood, anticoagulant peripheral blood and pre-diluted peripheral blood.

If select pre-diluted peripheral blood mode, first add 20 $\mu$ l peripheral blood at the diluting cup, then click “Diluent” button, a message box as following will appear:

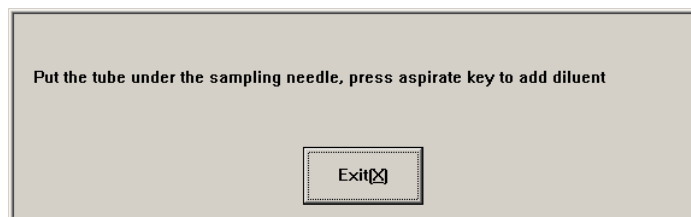

Fig.3-5 Add diluent

Press the aspiration key will add 700 $\mu$ l diluent to the diluting cup to complete the dilution out of instrument, the analyzer will aspirate 300 $\mu$ l diluentd sample for counting.

The test procedures are as following:

1. Put sample cup under sampling needle, press aspiration key, the instrument aspirate blood sample, wait until sampling needle rises inside instrument, remove sample cup.
2. Instrument begins to analyze sample, frame top message box shows “Being tested...”, after test, parameter, test result and histogram will be shown as follows:

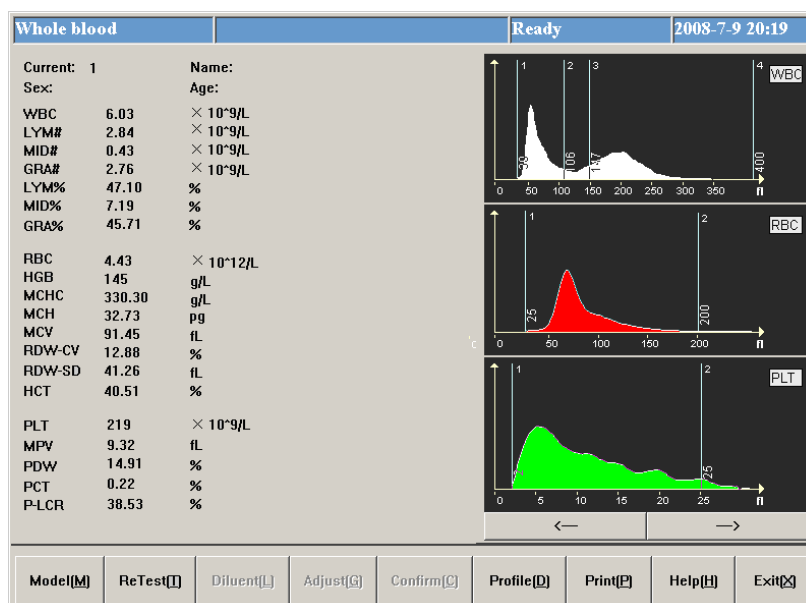

Fig.3-6 Blood sample counting screen

If "Print instantly" setting is selected, the instrument will print analysis result automatically after test ends.

If counting and analysis operation environment is below 15°C or over 35°C, the analysis result of the blood sample will be unreliable; the "Temperature Low" or "Temperature high" alarm will appear in message field of screen.

If block hole or bubble appears during counting and analysis, "Block hole" or "Bubble" alarm will appear in message field of screen.

If the remain volume of reagent is not enough, the message field will appear "Reagent volume not enough", it will also indicate which reagent is not enough such as diluent, cleanser and Lyse.

If test result exceeds system output range, parameter result will be shown as "---", then check validity of test sample.

- Note:**
- (1) *if sample splashes out of sample cup, please make necessary protection when cleaning, never touch sample directly.*
  - (2) *Please check remaining reagent amount periodically, if aspiration tube fails to aspirate thoroughly, please replace reagent.*
  - (3) *Sampling needle movement may cause body injury, watch out during aspiration.*

### 3.4.3 Parameter prompt message

H+: indicates that parameter test result is higher than maximum of predetermined pathogenic value.

L-: indicates that parameter test result is lower than minimum of predetermined pathogenic value.

H: indicates that parameter test result is less or equal to maximum pathogenic value, greater than maximum of normal value.

L: indicates that parameter test result is greater or equal to minimum of pathogenic value,

less than minimum of normal value.

#### 3.4.4 Histogram prompt message

LF1: prompts that region on the left side of lymphocyte peak is abnormal, possibly because of: platelet coagulation, giant platelet, plasmodium, nucleated red blood cell, non-lysed red blood cell, abnormal lymphocyte, cryoglobulin.

LF2: prompts that lymphocyte peak and intermediate cell region are abnormal, possibly because of: heteromorphic lymphocyte, plasma cell, atypical cell, initial cell, eosinophils and basophiles population.

LF3: prompts that the region between intermediate cell area and neutrophil peak is abnormal, possibly because of: immature granulocyte, abnormal cell and eosinophils.

LF4: the region on the right side of neutrophil is abnormal, possibly because of: granulocytosis.

PF1: the region on the right side of platelet is abnormal, indicating probable existence of: large platelet, platelet aggregate, small red blood cell, cell fragment and fibrous protein.

PF2: the region on the left side of platelet is abnormal, indicating probable existence of: small platelet cell fragment, red blood cell inclusion body and electronic noise interference.

#### 3.4.5 Adjust histogram

When WBC, RBC, PLT automatic classification result fails to meet requirement, the operator may adjust histogram. Procedure is as follows:

1. In sample test menu, click "Adjust" button, histogram selection frame pops up, as shown below:

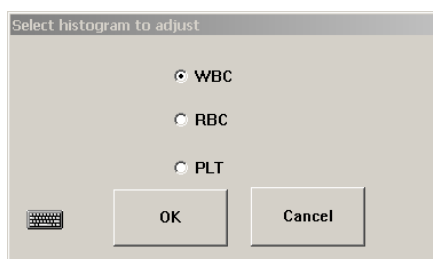



Fig.3-7 Histogram selection

Select histogram to adjust, click "OK" to return; click Cancel, then no histogram will be chosen. To adjust histogram without external keyboard, click "" to open soft keyboard.

2. Use mouse or keyboard number key "1", "2", "3" to choose type line, press "←" to move left, "→" to move right. Meanwhile current volume is shown on left-move type line. WBC diagram has only 2 sign lines to adjust, both sign lines of RBC and PLT can be adjusted.
3. After adjustment, click "OK" button, confirmation frame will pop up as below:

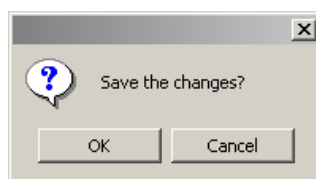

Fig.3-8 Adjust confirmation

Click "OK" button to save adjust result, click "Cancel" button to cancel this adjustment result.

#### **3.4.6 Print**

Before sample test, please set up printer and print format in system setting module, see detail in Chapter 7 "System Setting". Click "Print" to print this test result.

---

**Warning: during test, please do not replace reagent.**

---

## 4 Quality Control

Quality control reflects system accuracy and repeatability. Available instrument quality control program provides reliable and efficient way to check and prevent possible system error. If there is system error, sample analysis result will be unreliable. To maintain accurate analysis result, discover and eliminate instrument measurement system error in time, it is recommended to make regular quality control of instrument.

provides three QC methods, L-J QC, X-B QC and X-R QC.

### 4.1 L-J QC

In main screen, click "QC" button, choose 20 QC files of "L-J QC". The system can control 20 parameters at a time. L-J QC uses QC samples for QC analysis.

#### 4.1.1 L-J QC setting

Item	Targets	Limits	Item	Targets	Limits
WBC	9.70	0.30 ×10 <sup>9</sup> /L	RBC	4.21	0.50 ×10 <sup>12</sup> /L
LYM#	4.30	0.30 ×10 <sup>9</sup> /L	HGB	111.00	10.00 g/L
MID#	0.70	0.30 ×10 <sup>9</sup> /L	MCHC	34.40	2.00 g/L
GRA#	4.70	0.30 ×10 <sup>9</sup> /L	MCH		p9
LYM%	44.70	2.00 %	MCV	84.30	0.80 fL
MID%	7.00	3.00 %	RDW-CV		%
GRA%	48.50	3.00 %	RDW-SD		fL
PLT	278.00	20.00 ×10 <sup>9</sup> /L	HCT	35.50	3.00 %
MPV		fL			
PDW	15.00	3.00 %			
PCT	0.10	0.10 %			
P-LCR	0.22	0.10 %			

Fig.4-1 L-J QC setting

- Save: select QC file, enter lot No., validity period, parameter targets value and limits, click "save" button, save QC data of current QC file, if there is data in this QC file, then update.
- Rules: select QC rules of this QC file, you can unselect, select one or more. System will make out-of-control determination and alarm in QC test according to these rules. QC rules frame is shown below:

QC Rule

- Once exceed 3SD
- Consecutive twice exceed 2SD
- Consecutive 5 times at the same side of bias between 1SD and 2SD
- Consecutive 7 times at the same side of bias

OK Cancel

Fig.4-2 L-J QC criterion

- Items: user may select all parameters for QC, or select part of parameters for QC.
- Delete: delete QC data of QC file currently selected.
- Send: use instrument RS-232 serial port to transfer QC data of QC file currently

selected to designated receiver. Prior to transfer, please use RS-232 serial port cable to connect to equipment ready to receive data, start up and set up receiver software parameters. For setting of instrument transferring terminal parameter, please refer to Chapter 7 "System Setting".

- Help: to display system help.
- Exit: return to main screen.

#### 4.1.2 L-J QC run

After QC parameter setting of selected QC file is done, QC analysis of this QC file can start. In main screen, select QC file, enter QC Run screen as shown below:

The screenshot shows a window titled "L-J QC Run(QC 1)" with a header bar containing "Lot: 78S4" and "Expiry: 2008-12-31". Below the header is a table with columns for "No.", "Targets", and "Limits". The table lists various hematology parameters with their corresponding target and limit values. At the bottom of the window, there are three buttons: "Delete[D]", "Help[H]", and "Exit[X]".

No.	Targets	Limits
Date		
Time		
WBC	9.70	0.30
LYM#	4.30	0.30
MID#	0.70	0.30
GRA#	4.70	0.30
LYM%	44.70	2.00
MID%	7.00	3.00
GRA%	48.90	3.00
RBC	4.21	0.50
HGB	111.00	10.00
MCHC	34.40	2.00
MCH	0.00	0.00
MCV	84.30	0.80
RDW-CV	0.00	0.00
RDW-SD	0.00	0.00
HCT	36.50	3.00
PLT	278.00	20.00
MPV	0.00	0.00
PDW	15.00	3.00
PCT	0.10	0.10
P-LCR	0.22	0.10

Fig.4-3 L-J QC run

1. Have QC sample ready, press Aspiration key to start test.
2. After test, QC run result will be shown under current QC number column. If fault alarm occurs in test, this test result may be inaccurate. You can click "Delete" button to delete this test result. Eliminate related fault before next run. If out-of-control rule is set during QC setting, in case of inconformity with QC rules in running, the system will prompt, the user can delete current QC run result, and test again.
3. Each QC file can save at most 500 QC results. Press "Return" button to return to main screen.

#### 4.1.3 L-J QC list

The instrument can look up QC run data in list. In main screen, select QC file, enter QC list, as shown below:

L-J QC List(QC 1)								
No.	Targets	Limits	1	2	3	4	5	6
Date			2008-05-24	2008-05-28	2008-05-28	2008-05-28	2008-05-29	2008-05-29
Time			15:25:59	08:40:18	09:11:50	09:12:50	14:12:50	14:13:20
WBC	9.70	0.30	9.60	9.75	9.70	9.65	9.78	9.50
LYM#	4.30	0.30						
MID#	0.70	0.30						
GRA#	4.70	0.30						
LYM%	44.70	2.00						
MID%	7.00	3.00						
GRA%	48.50	3.00						
RBC	4.21	0.50	4.20	4.30	4.15	4.25	4.20	4.00
HGB	111.00	10.00	115.00	111.00	108.00	120.00	117.00	120.00
MCHC	34.40	2.00						
MCH	0.00	0.00						
MCV	84.30	0.80	82.02	51.96	48.82	70.30	60.60	60.60
RDW-CV	0.00	0.00						
RDW-SD	0.00	0.00						
HCT	35.50	3.00						
PLT	278.00	20.00	280.00	278.00	265.00	276.00	280.00	279.00
MPV	0.00	0.00						
PDW	15.00	3.00						
PCT	0.10	0.10						
P-LCR	0.22	0.10						

Fig.4-4 L-J QC list

The instrument will display 20-parameters QC result, if some parameters are not controlled, the corresponding column shall be blank.

Send function can transfer part or all of the L-J QC data to external equipment. Use mouse or touch pen to click list column, select one group of QC data. Using keyboard Ctrl key or Shift key, multiple columns can be selected. You can send all data, click "Send" button, open transfer dialog box as follows:

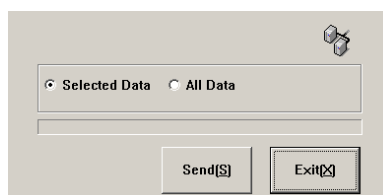

Fig.4-5 L-J data transfer

Select data to be submitted, click "Send".

Click "Delete" button, then delete confirmation dialog box pops up, after confirmed, you can delete part of or all QC data. Selection method of part of data is the same as data transfer.

#### 4.1.4 L-J QC chart

QC chart displays QC data distribution in graphs, to facilitate understanding of instrument deviation trend. In main screen, select QC file, open QC chart screen, as follows:

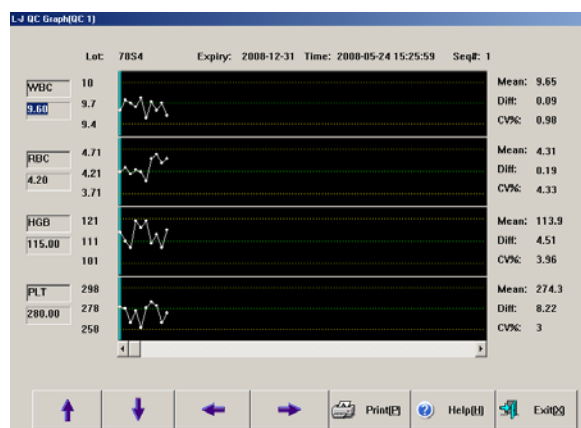

Fig.4-6 L-J QC chart

- ✧ Lot No.: lot Number of QC sample corresponding to QC file.
- ✧ Expiry: validity period of QC sample.
- ✧ Time: test time of datum corresponding to QC point.
- ✧ Seq#: sequence number of current QC point in all QC data points.

Each screen displays four-parameter QC chart, Mean (average), Diff (standard deviation), CV (variation coefficient) of each parameter.

Three values on the left of QC chart are, from top to bottom: QC sample target value + deviation, QC sample target value, QC sample target value - deviation, respectively.

Press “↓”, “↑” keys on keyboard or frame to switch between items.

Press “←”, “→” keys on keyboard or frame, QC data of different sequence Numbers can be shown.

Press “Print” button to print out one current group of QC data.

## 4.2 X-B QC

X-B QC does not use QC sample, same as QC of QC sample, it belongs to instrument quality monitoring method, they can reflect machine inspection quality from different aspects, and not interchangeable. X-B QC data stem from random sample, not classified according to disease type. The given value and upper and lower limits comprise a reference range, observe trend of each lot of X-B values in reference range.

The instrument makes X-B QC of all 20 parameters, quantity of samples for X-B numeric analysis in each lot is within 20-200, the default is 20.

### 4.2.1 X-B QC setting

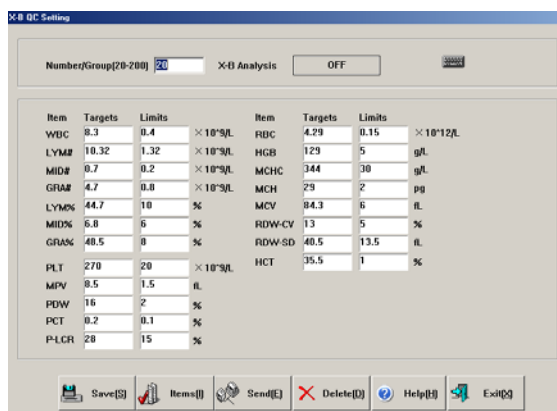

Fig.4-7 X-B QC setting

If X-B analysis is “On”, samples are tested and also taken as X-B QC analysis data.

X-B QC target value and limits are calculated and filled out by user manually. Parameter target value is the average of statistic calculation result of sample data after test in this region, samples shall reach a certain amount, its recommended quantity is above 1000, and sample source shall be verified to be random, data reference values of different regions will be different. Limits choice is recommended to be 5%-10%.

- Save: save QC setting data.
- Items: user can select QC of all parameters, or select QC of some parameters.
- Delete: delete X-B QC setting data.
- Send: use instrument RS-232 serial port to transfer X-B QC setting data to designated receiver. Before sending, please use RS-232 serial port cable to connect to equipment



to receive data, start up and set up receiver software parameters. For instrument transfer terminal parameter setting, please refer to Chapter 7 “System Setting”.

- Help: display system help.
- Exit: return to main screen.

### 4.2.2 X-B QC list

The instrument can save at most 2000 X-B QC data, open X-B QC list, as shown below:

No	Targets	Limits	1	2	3	4	5	6
Date			2008-07-03	2008-07-03	2008-07-03	2008-07-03	2008-07-03	2008-07-03
Time			09:28:21	10:12:35	10:38:45	10:38:45	10:38:45	10:38:45
WBC	9.30	0.40	9.70	9.50	9.80	9.80	9.80	9.80
LYMF	10.32	1.32	4.51	4.51	4.26	4.26	4.26	4.26
MID#	0.70	0.20	0.49	0.57	0.49	0.49	0.49	0.49
GRA#	4.70	0.80	4.86	5.18	5.12	5.12	5.12	5.12
LYMF%	44.70	10.00	45.74	43.95	43.17	43.17	43.17	43.17
MID%	6.80	6.00	4.94	5.60	4.98	4.98	4.98	4.98
GRA%	48.50	8.00	49.32	60.45	51.85	51.85	51.85	51.85
RBC	4.29	0.15	4.24	4.46	4.30	4.30	4.30	4.30
HGB	129.00	5.00	128.00	130.00	132.00	132.00	132.00	132.00
MCHC	344.00	30.00	408.07	372.56	369.13	369.13	369.13	369.13
MCH	29.00	2.00	36.68	33.84	33.41	33.41	33.41	33.41
MCV	84.30	6.00	95.07	96.07	96.56	96.56	96.56	96.56
RDW-CV	13.00	5.00	11.36	11.17	11.23	11.23	11.23	11.23
RDW-SD	40.50	13.50	39.31	39.09	39.16	39.16	39.16	39.16
RCT	35.50	1.00	40.62	43.20	43.94	43.94	43.94	43.94
PLT	270.00	20.00	270.00	278.00	265.00	265.00	265.00	265.00
MPV	8.50	1.50	9.39	8.65	9.54	9.54	9.54	9.54
PDW	16.00	2.00	16.33	18.75	15.93	15.93	15.93	15.93
RCT	0.20	0.10	0.42	0.33	0.42	0.42	0.42	0.42
P-LCR	28.00	15.00	41.95	35.41	43.21	43.21	43.21	43.21

Fig.4-8 X-B QC list

The instrument displays 20-parameter QC result, if some parameters are not controlled, the corresponding column shall be blank.

Upper limit of QC data columns of X-B QC list shown at a time is 200, if data are more than 200 columns, they can be viewed by switching using “←” and “→”.

Sending function can transfer some or all X-B QC data to external equipment. Operation method is the same as data transfer in “4.1.3 L-J QC list”.

In list frame, click “Delete” button, delete confirmation dialog box pops up. After confirmed, some or all QC data will be deleted.

### 4.2.3 X-B QC chart

The system provides graphic to look up X-B QC analysis data, as shown below:

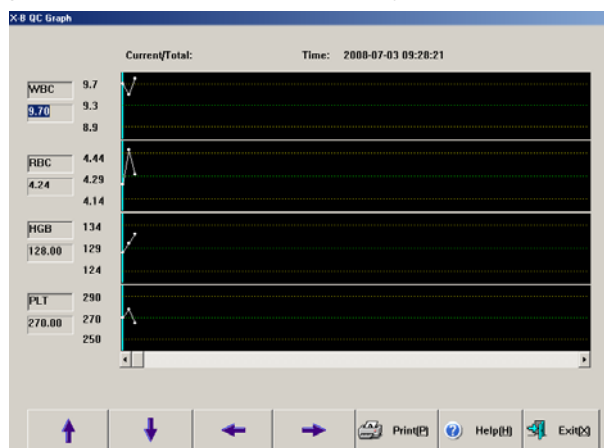

Fig.4-9 X-B QC chart

- ◇ Current/Total: to display current QC data point location and X-B QC analysis total.
- ◇ Time: test time of data corresponding to QC point.

Each screen displays four-parameter QC chart. Three values on the left of QC chart are,

from top to bottom: target value + deviation, target value, target value - deviation.

Press “↓”, “↑” keys on keyboard or frame to switch between parameters.

Press “←”, “→” keys on keyboard or frame to display QC data of various serial numbers.

Press “Print” button to print out one current group of QC data.

### 4.3 X-R QC

X-R QC, or mean - range QC, is common quality control method in industry, an efficient way to determine and forecast abnormal fluctuation of quality, it complements with L-J QC each other. X-R use QC sample for QC analysis.

X-R QC primarily use control chart to reflect QC data stability, its QC chart is a combined chart.

#### 4.3.1 X-R QC setting

Before running X-R QC, necessary QC parameter setting shall be done, setting screen is as follows:

Fig.4-10 X-R QC setting

- Lot No.: lot number of QC object.
- Expiry: validity period of QC object
- Group No.: 2-60, default is 20.
- Number of samples in each group: 2-10, default is 5.
- Save: select QC file, input lot No., validity period, and parameter target value and limits, click “Save” button to save QC data of current QC file, if this QC file has data, then update.
- Delete: delete QC data of currently selected QC file.
- Send: use instrument RS-232 serial port to transfer QC data of currently selected QC file to designated receiver. Before sending, please connect to equipment to receive data with RS-232 serial port cable, start up and set up receiver software parameters. For instrument transfer terminal parameter setting, please refer to Chapter 7 “System Setting”.
- Help: to display system help.
- Exit: return to main screen.

#### 4.3.2 X-R QC run

After QC parameter setting of selected QC file, QC analysis of this QC file can begin. In main screen, select QC file, go to QC run screen, as shown below:

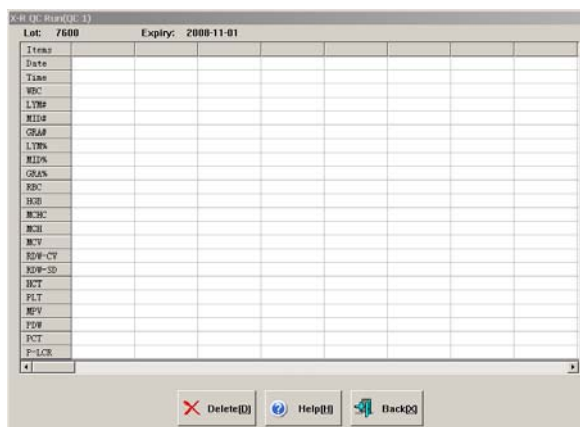

Fig.4-11 X-R QC run

1. Have QC sample ready, press Aspiration key to start test.
2. After test, QC results will be shown under current QC number column. If there is fault alarm in test, this test result may be inaccurate. You can click “Delete” shortcut key to delete this test result, eliminate related fault, before next test.
3. Each QC file can save at most (group numbers preset in QC setting × number of samples in each group) QC results. Press “Exit” button to return to main screen.

### 4.3.3 X-R QC list

The instrument can look up X-R QC data by listing. In main screen, select QC file, go to QC list, as follows:

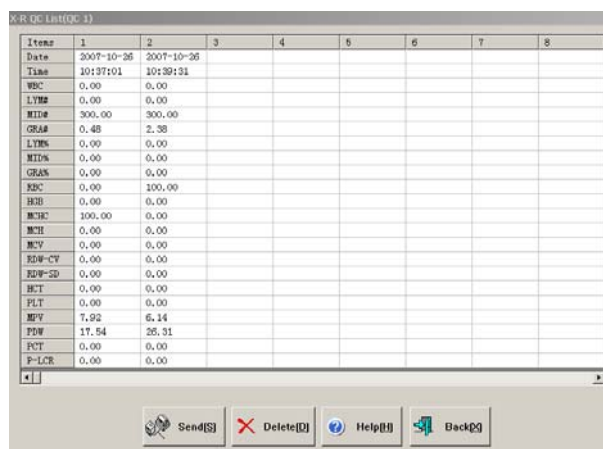

Fig.4-12 X-R QC list

The instrument will display 20-parameter QC result.

Click “Send” button, some or all QC results can be transferred to external receiver. Operation method is the same as data transfer in “4.1.3 L-J QC list”.

Click “Delete” button, deletion confirmation dialog box pops up. After confirmed, some or all QC data will be deleted.

### 4.3.4 X-R QC chart

X-R QC chart can visually reflect instrument stability, when instrument is under control, points in chart will randomly distributed on both sides of centerline, the farther from centerline, the nearer to upper/lower control limits, there will be fewer points. Graphic screen is as follows:

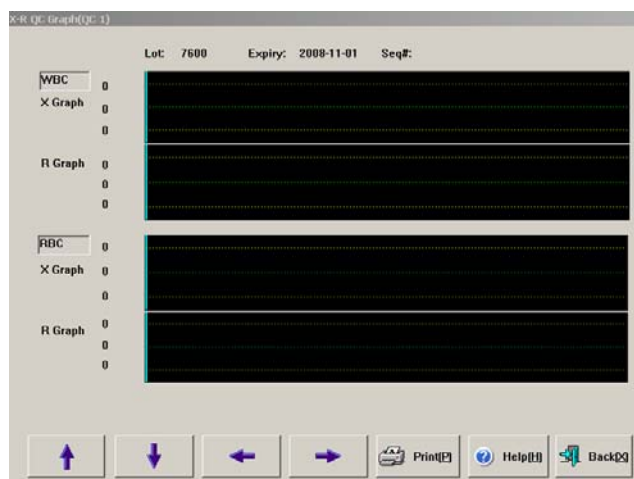

Fig.4-13 X-R QC chart

- ◇ Lot No.: lot number of QC object
- ◇ Expiry: validity period of QC object
- ◇ Seq#.: sequence number of current QC point

Each screen displays two-parameter QC data distribution. QC chart of each parameter is composed of X chart and R chart, reflecting QC data mean and range fluctuation respectively. Three values on the left of X chart are, from top to bottom:  $\bar{\bar{X}} + A_2 \bar{R}$ ,  $\bar{\bar{X}}$ ,  $\bar{\bar{X}} - A_2 \bar{R}$ , respectively. Three values on the left of R chart are, from top to bottom:  $D_4 \bar{R}$ ,  $\bar{R}$ ,  $D_3 \bar{R}$ , respectively; where,  $\bar{\bar{X}} = \sum_{i=1}^k \bar{X}_i / K$ ,  $\bar{X}_i$  is mean value of group i,  $\bar{R} = \sum_{i=1}^k R_i / K$ ,  $R_i$  is the difference between maximum and minimum of group i, K is subgroup quantity,  $A_2$ ,  $D_4$ ,

$D_3$  are coefficients determined by number of samples in each group.

Press “↓”, “↑” keys on keyboard or frame to switch between parameters.

Press “←”, “→” keys on keyboard or frame to display QC data of various sequence numbers.

Press “Print” button to print out one current group of QC data.

## 5 Calibration

Before delivery, all instruments have been subjected to strict test and calibration. But during transportation and using, test result may drift due to different reasons; instrument calibration purpose is to ensure test result accuracy.

In order to guarantee instrument test accuracy and get stable and reliable test result, instrument must be calibrated in following cases.

1. First installation for use and reinstallation at other place.
2. Instrument has been repaired.
3. Deviations in QC results.

---

***Note: calibration sample shall adopt The manufacturer designated commercial calibration sample, stores and uses as required. Before making sure that all calibrations have been done correctly, do not use test results for medical and clinical diagnosis.***

---

### 5.1 Preparation before calibration

Commercial calibration sample can be used to calibrate this instrument. All mathematic calculations related with calibration can be done by instrument automatically, calibration coefficient is automatically saved. has three sets of calibration coefficients, anti-coagulating whole blood, anti-coagulating peripheral blood and pre-diluted peripheral blood; anti-coagulating whole blood, anti-coagulating peripheral blood and pre-diluted peripheral blood are calibrated separately.

Before instrument calibration, you shall check in following steps, make sure machine works in normal status, if any problem is found, stop calibration.

- 1) Check instrument and reagent, make sure that instrument is in normal status, reagent is sufficient, material needed is complete.
- 2) Make blank test, make sure that blank test value meets requirement.
- 3) In counting screen, use median blood sample to repeat test, make sure that instrument works within precision range.

### 5.2 Manual calibration

In main screen, select manual calibration, the system goes to manual calibration screen as shown below:

Sample Type

Whole blood
  Peripheral blood
  Pre-diluted peripheral blood

Item	Default	Current coef.	Calib.Date	Item	Default	Current coef.	Calib.Date
WBC	100 %	100.00 %	2009-03-25	RDW-SD	100 %	100.00 %	2009-03-25
RBC	100 %	100.00 %	2009-03-25	PLT	100 %	100.00 %	2009-03-25
HGB	100 %	100.00 %	2009-03-25	MPV	100 %	100.00 %	2009-03-25
MCV	100 %	100.00 %	2009-03-25	PDW	100 %	100.00 %	2009-03-25
RDW-CV	100 %	100.00 %	2009-03-25	P-LCR	100 %	100.00 %	2009-03-25





 Save(S)
  Print(P)
  Exit(X)

Fig.5-1 Manual calibration

Manual calibration procedure is as follows:

1. In Sample Test menu, use calibration sample to test several times (at least three).
2. Record the tested data.
3. Calculate new calibration coefficient

Calculate new calibration coefficient as per formula below:

$$\text{new\_calibration\_coefficient} = \frac{\text{current\_calibration\_coefficient} \times \text{calibration\_sample\_reference\_value}}{\text{Mean\_of\_test\_values}}$$

4. In Manual Calibration screen, select sample type, input new calibration coefficient in calibration input box, input calibration time in calibration time box. If running auto-calibration, the parameter calibration time will be automatically updated to the time of automatic calibration.
5. Click "Save" button to save current calibration result. Click "Exit" button, the system will not save result, and directly return to main screen.

### 5.3 Auto-calibration

When automatic calibration is selected, after testing calibration sample, the instrument can automatically calculate new calibration coefficient. Auto-calibration procedure is as follows:

1. Set up calibration sample, select parameters to calibrate;
2. Test calibration sample;
3. Determine calibration coefficient.

Auto-calibration screen is as follows:

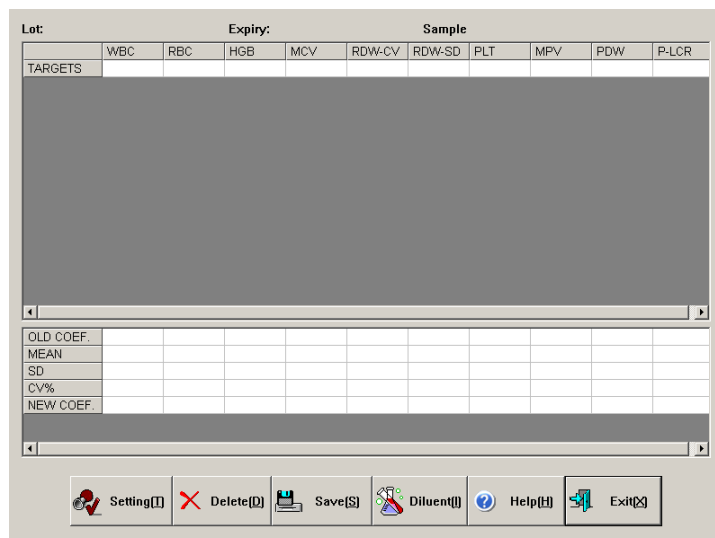

Fig.5-2 Auto-calibration

At first, calibration sample is to be set up, click “Setting” button, open auto-calibration setting menu, as shown below:

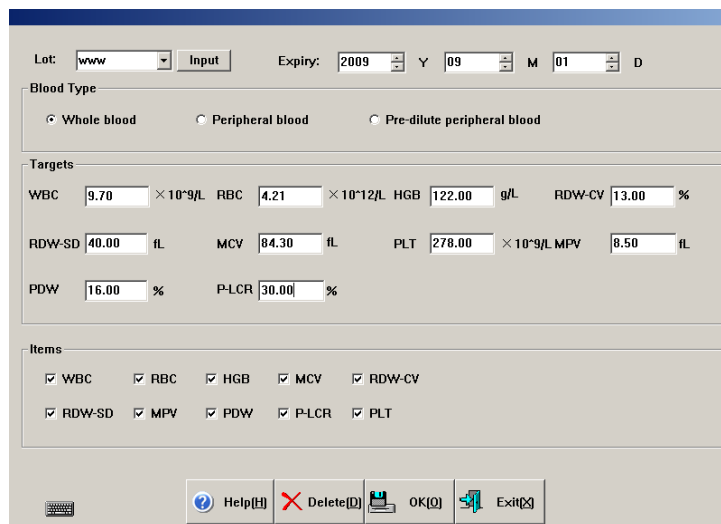

Fig.5-3 Auto-calibration setting

- Lot No.: lot number of calibration sample, input and save, on next logon, you can select from dropdown list, check or modify data of this lot no. Click “Input” button to input lot No.
- Expiry: validity period of calibration sample, if validity period is less than current system date, when confirmed to return, the instrument will give alarm of using another calibration sample to calibrate.
- Blood type: blood type of calibration sample.
- Targets: reference value of each parameter of calibration sample.
- Calibration parameter: parameter to calibrate.

Click “Delete” button, current calibration sample setting data can be deleted. Click “OK” to save current lot number data and exit. Click “Cancel” button, the system will not function, and directly return to Auto-calibration running screen.

After setting, return to screen as shown in Fig.5-2, start calibration test, the process is as follows:

- 1) Have calibration sample ready, press Aspiration key to start test.
- 2) After test, calibration result will be shown in current test number column.
- 3) Repeat test, the instrument allows 20 runs at most.
- 4) Statistic results and new calibration coefficient will be shown in table below frame after each test automatically.
- 5) Unsatisfactory test data rows can be deleted at any time.

If deciding to use new calibration coefficient, click "Save" button, the system will save new calibration coefficient.



## 6 Results

After test of each sample, the system automatically saves test data, parameter test values and histograms of at most 50000 samples. User can check parameter test data and histograms of all samples, print, delete, modify and retrieve sample data of designated condition.

In main screen, click “RESULTS” button, open history data list menu, as shown below:

No.	20080505009	20080505010	20080505011	20080505012	20080505013	20080505014	
Date	2008-05-05	2008-05-05	2008-05-05	2008-05-05	2008-05-05	2008-05-05	
Time	08:10:23	08:33:40	08:35:00	08:52:48	08:56:46	08:57:48	
WBC	0.06 L	0.07 L	0.05 L	0.03 L	9.63	0.07 L	
LYM#	- - -	- - -	- - -	- - -	4.12 h	- - -	
MID#	- - -	- - -	- - -	- - -	0.90	- - -	
GR4#	- - -	- - -	- - -	- - -	4.61	- - -	
LYM%	- - -	- - -	- - -	- - -	42.74	- - -	
MID%	- - -	- - -	- - -	- - -	9.34	- - -	
GR4%	- - -	- - -	- - -	- - -	47.92	- - -	
RBC	0.00 L	0.00 L	0.00 L	0.00 L	4.08	0.00 L	
HGB	1 L	3 L	6 L	1 L	158	1 L	
MCHC	- - -	- - -	- - -	- - -	329.16	- - -	
MCH	- - -	- - -	- - -	- - -	30.03	- - -	
MCV	- - -	- - -	- - -	- - -	91.07	- - -	
RDW-CV	- - -	- - -	- - -	- - -	11.55	- - -	
RDW-SD	- - -	- - -	- - -	- - -	39.57	- - -	
HCT	- - -	- - -	- - -	- - -	43.15	- - -	
PLT	7 L	19 L	17 L	5 L	282 h	3 L	
MPV	6.56 l	4.26 L	4.54 L	- - -	12.46 h	- - -	
PDW	25.98 H	47.39 H	43.63 H	- - -	8.91 l	- - -	
PCT	0.00 L	0.01 L	0.01 L	- - -	0.39 h	- - -	
P-LCR	10.34 l	2.50 L	5.56 L	- - -	100.00 H	- - -	

Total records: 1431 Current Records: 431 [Page 3]

<< >> Select Send Locate Search Delete Detail Print Order Back

Fig.6-1 History record list

Home screen of system displays the latest 500 records, “H”, “L” or “H+”, “L-” after parameter indicates that test result exceeds upper limit or lower limit of system setting parameter pathogenic value or normal value.

Test result with “- -”, indicates that result is beyond test range or fault occurs during test.

If history record number is greater than 500, you can click “<<-” and “->>” buttons to switch between browsing data.

- Select

Click “select” button, open select dialog box as follows:

Start:

End:

Fig.6-2 Select dialog box

Input record sequence numbers to choose in starting point and end point edit boxes, click “OK”, if the same value is entered in starting point and ending point edit boxes, then the record this value corresponds to is selected.

Click “Cancel” button, the system will not select any record.

- Send

It provides data transfer function, data selecting methods: a) use select function. b) Use mouse or touch pen to click list column, select one history data; using keyboard Ctrl key

or Shift key, you can select multiple columns. If no data are selected, all data can be sent. Click "Send" button, open transfer dialog box as follows:

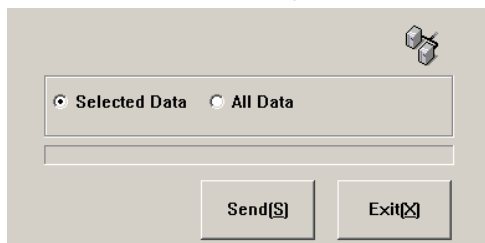

Fig.6-3 Data transfer

Select data to send, click "send".

- Locate

Locate function is used to jump to designated record location, click "Locate" button, open locating dialog box as follows:

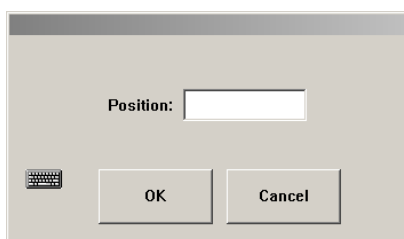

Fig.6-4 Locating dialog box

Input a number ranged between 1 and 500 into position box, click "OK". Click "Cancel" to exit directly.

- Search

Search function allows user to search required record according to designated condition, click "Search" button, open search dialog box as follows:

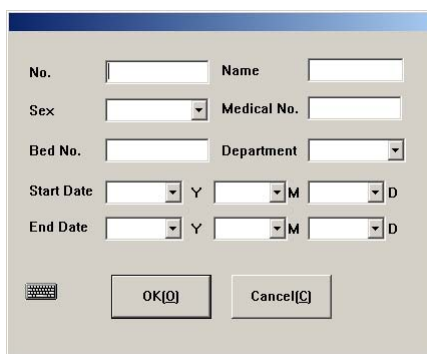

Fig.6-5 Search condition

Sample no. is the only identification of history record. If input sample no., other conditions are disabled. User can use one or multiple condition to retrieve, input message, click "OK", if there is compliant record, it will be shown in history record list. If there is no compliant record, the system will give a message.

- Delete

Delete function can be used to delete selected data and all history data. Data can be selected in following methods: a) use select function. b) Use mouse or touch pen to click list column, select one history data. Using keyboard Ctrl key or Shift key, multiple

columns can be selected. If no data are selected, the system will prompt to delete all sample data.

- **Print**  
Print function prints selected history data according to system setting print mode. See print setting in Chapter 7 “System Setting”.
- **Detail**  
“Detail” function is used to check detail data message of a certain sample, select one record in history list, click “Detail” button, and go to Sample Detail Message Review menu as follows:

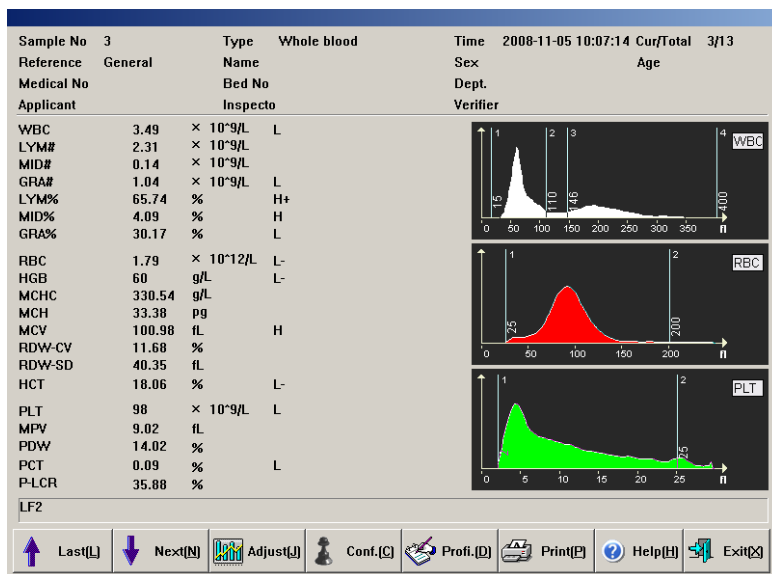

Fig.6-6 Sample history data

This menu displays sample basic message, test value and histogram, click “Previous item”, “Next item” buttons to check sample. To adjust histogram, run as per 3.4.5.

To modify sample basic message, click “Data” button, go to Data Edit menu, see detail in “3.4.1 Sample data edit”.

In sample history data menu, click “Print” button, the instrument will print out current sample history data according to system setting print mode. See print setting in Chapter 7 “System Setting”.

## 7 System Setting

System setting is used to set up system parameters, in main screen, click “Setting”, and go to System Setting menu as follows:

The screenshot shows the 'Sys. Setting' window with the following fields and options:

- Serial Number:** 20080818001
- Print Section:**
  - Printer:  Internal Printer,  External Printer
  - Print instantly
  - Print items: Set, Printer properties
  - External Printer: HP LaserJet 1022
  - Printout: HALF PAGE WITH HISTOGRAMS
  - Hospital: [Empty field]
- Time Section:**
  - Y: 2008, M: 11, D: 04
  - H: 15, M: 17, S: 06
- Special Section:**
  - Startup Blank Test
  - Clean Freq(times): 60
  - Pre-diluted test mode inform
  - Transmit instantly
- Bottom Buttons:** Save(S), Other(O), Help(H), TouchScreen(T), Exit(X)

Fig.7-1 System setting

### 7.1 General setting

- Serial number: machine serial number, used to identify one instrument.
- Time: input or use adjust bar on the right to modify setting item, set up new time only after saving.
- Language: used to switch between different system languages. If one wishes to still use current setting after next startup, please save language setting.
- Print setting:
  1. Printer: select internal Print, the instrument's internal thermal printer will output result. Meanwhile, you can select Print instantly or not, if selecting Print instantly, the test result will be automatically printed once the sample test ends. Select External Print, the system will print by external printer selected.
  2. Print item: click “Set” button to open the print item setting menu, you can select the parameters need printing. The system provides 3 templates for user.
  3. Printout: internal printer has 2 formats, with histogram, without histogram. Parameter names refer to name of 20 hematology parameters. With histogram means printout includes histogram, without histogram means printout does not include histogram.
  4. Unit name: will be printed in report title.
- Special:
  1. Startup blank test: select startup blank test, then start up program for blank test, otherwise skip blank test.
  2. Clean Freq (times): in this box, input test sample quantity, when instrument tested sample number is above this value, the instrument will run cleaning procedure one

- time. If it is set zero, it will not execute automatic cleaning.
3. Pre-diluted test mode inform: select the box, before pre-diluted peripheral blood test, inform message will popup.
  4. Transmit instantly: After sample test, the result will transfer to the computer by RS-232 serial port synchronously.

## 7.2 Other

Click “Other” button; open the menu as follows:

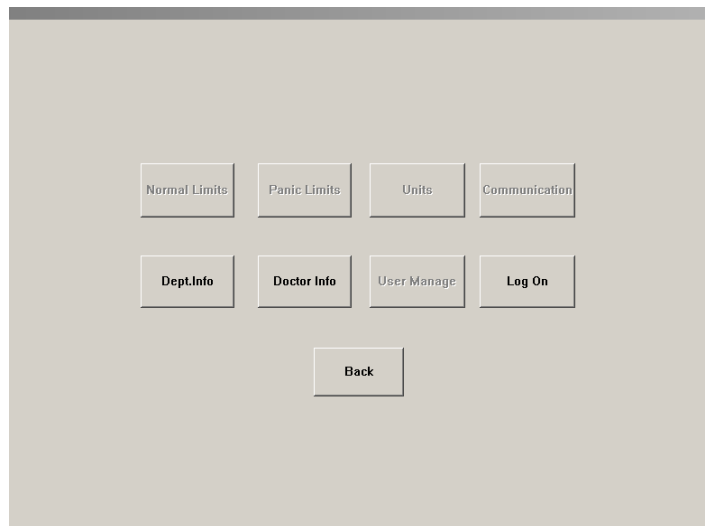

Fig.7-2 Other setting

### 7.2.1 User setting

The system has three levels of users now, system administrator, advanced user and common user, with varied priorities. Default is common user, then some settings are disabled, to enable these settings, please click “Log on” button, open logon dialog box as follows:

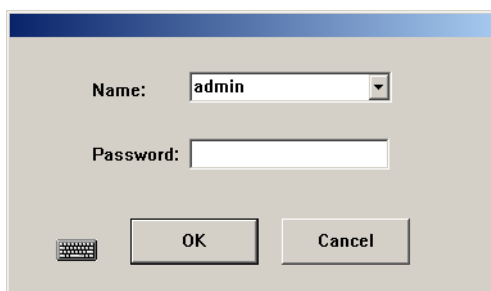

Fig.7-3 Logon dialog box

Select or input user account and password, click “OK” button, if you’re system administrator, then all functions in Other Setting screen will be enabled. System presets administrator user “Admin”, the password is 1008 (A few version’s password is 7600). New menu after system administrator logon is as follows:

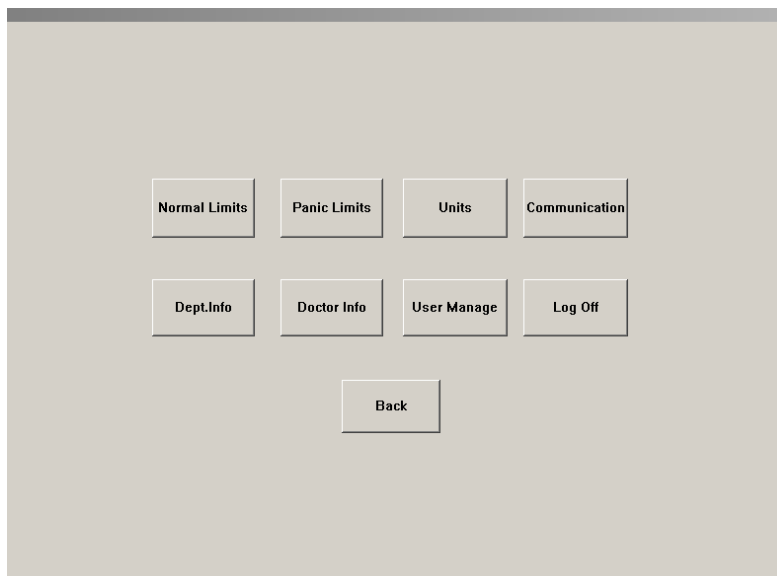

Fig.7-4 Other setting

Click “Log off” button, the user identity will be changed to common user.

**7.2.2 Normal limits**

Click “Normal Limits” button, open setting menu as follows:

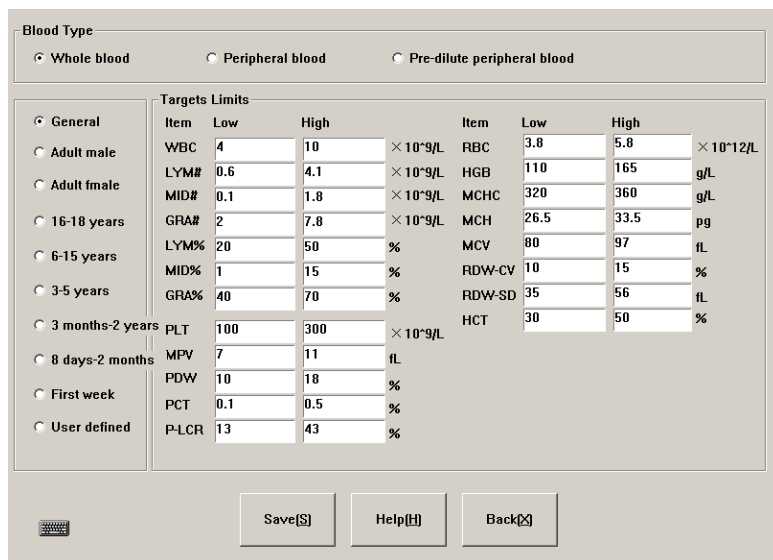

Fig.7-5 Normal value setting

Reference range of each parameter has been set before delivery of instrument, to modify parameter reference range, you can select blood type and population category, and fill in parameter lower limit and upper limit blanks, click “Save” button.

**7.2.3 Panic limits**

When parameter value exceeds normal value range, it does not definitely indicate that the subject is patient, when it falls within panic limits, the conclusion has to be made on specific case. Click “Panic limits” button, open setting menu as follows:

Blood Type  
 Whole blood     Peripheral blood     Pre-dilute peripheral blood

Targets Limits

General  
 Adult male  
 Adult female  
 16-18 years  
 6-15 years  
 3-5 years  
 3 months-2 yr  
 8 days-2 mor  
 First week  
 User defined

Item	Low	High	Item	Low	High		
WBC	2	15	× 10 <sup>9</sup> /L	RBC	2.5	7	× 10 <sup>12</sup> /L
LYM#	0.4	6	× 10 <sup>9</sup> /L	HGB	90	180	g/L
MID#	0.05	2.5	× 10 <sup>9</sup> /L	MCHC	280	450	g/L
GRA#	1	10	× 10 <sup>9</sup> /L	MCH	20	40	pg
LYM%	10	60	%	MCV	70	110	fL
MID%	0.5	25	%	RDW-CV	5	20	%
GRA%	30	80	%	RDW-SD	25	70	fL
PLT	60	350	× 10 <sup>9</sup> /L	HCT	25	70	%
MPV	5	15	fL				
PDW	5	25	%				
PCT	0.05	1	%				
P-LCR	10	55	%				

Save(S)    Help(H)    Back(X)

Fig.7-6 Panic limits

Reference range of each parameter has been set before delivery of instrument, to modify parameter reference range, you can select blood type and population category, and fill in parameter lower limit and upper limit blanks, click “Save” button.

**7.2.4 Units**

To change parameter unit, click “Units” button, open Units setting menu as follows:

Unit Setting

WBC, LYM#, MID#, GRA#:

LYM%, MID%, GRA%:

RBC:

HGB:

MCHC:

HCT:

MCV:

MCH:

RDW-CV:

RDW-SD:

PLT:

MPV:

PCT:

PDW, P-LCR:

OK    Cancel

Fig.7-7 Units setting

Totally units of 10 parameters can be set, WBC, LYM#, MID#, GRA# use the same unit. Select appropriate unit, and click “OK” to save and exit, click “Cancel”, the Units will not be changed.

**7.2.5 Communication**

Communication setting is used to set up each parameter value for serial port transfer interface, to check or modify these settings, click “Communication” button, open communication setting menu as follows:

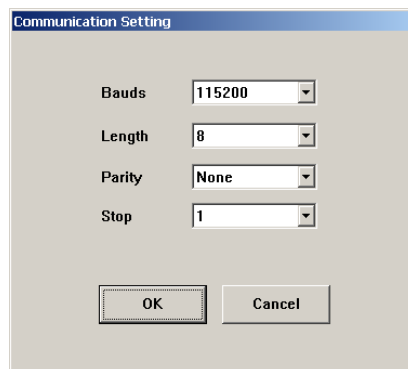

Fig.7-8 Communication setting

Instrument default values are: Baud rate: 115200, data digit: 8, calibration digit: None, stop digit: 1. to modify setting, click dropdown box, select other different value, click "OK" button.

### 7.2.6 Department information

Department information is used to set up department data of user unit, user message setting and sample data entry will use department message, preset these messages will speed up department data input. Click "Dept. Info" button, open department message menu as follows:

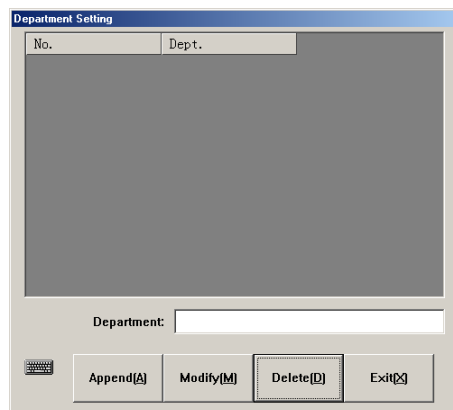

Fig.7-9 Department message setting

1. Append: click "Append" button to add one row of blank column, input department name in department column, click "Append" button, the added department message can be saved.
2. Modify: Select the column you want to modify, input new department name, click "Modify" button to update the info. If the input is blank, it will not update.
3. Delete: select one row or several rows of data, click "Delete" button, confirm, and delete selected department message.
4. Exit: return to other setting frame.

### 7.2.7 Doctor information

Doctor information is used to set up individual doctor data, which will be sued in sample data entry, preset these messages will speed up doctor data input. Click "Doctor Info" button, open doctor information menu as follows:



No.	Name	Dept.	Sender	Scrutator	Checker
1	Jack		N	N	N

Name:  Dept.:   Sender  Scrutator  Checker

Fig.7-10 Doctor setting

1. Append: click “Append” button to add one row of blank column, input name in name column, select department, sender, tester and checker from dropdown list. Set up department in department message type, “N” in sender, tester and checker boxes indicates that the doctor is not of this identity; “Y” indicates that this doctor has such identity.
2. Modify: Select a data column you want to modify, input new information of the doctor, click “Modify” to update the doctor’s information. If the input is blank, it will not update.
3. Delete: select one row or several rows of data, click “Delete” button, confirm, delete the selected doctor message will be deleted.
4. Exit: return to other setting frame.

## 8 System Information

System message provides several types of message about system; user can check system status through system message function module.

### 8.1 System status

On system message menu of main screen, click "System Info" key, the click "system status", go to system status menu as follows:

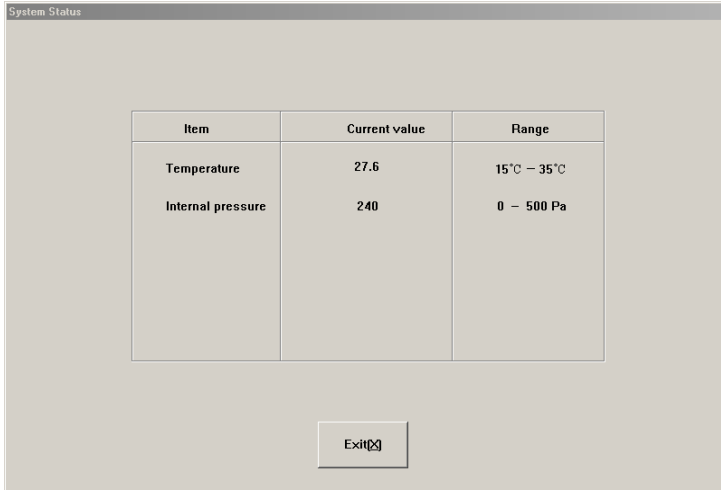

Item	Current value	Range
Temperature	27.6	15°C - 35°C
Internal pressure	240	0 - 500 Pa

Exit

Fig.8-1 system status

The system provides two test parameters now, if test value is out of reference range, related troubleshooting is necessary.

### 8.2 System log

System log records main events and results of instrument during running. In system info menu of main screen, click "Log", go to system log frame, you can check log message as follows:

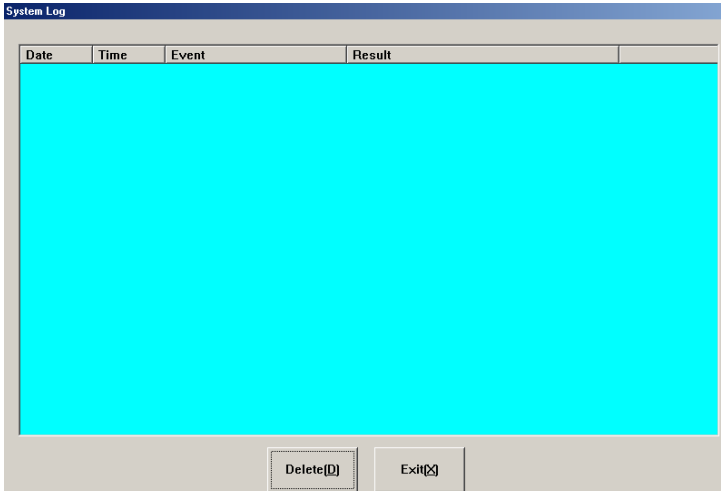

Date	Time	Event	Result
------	------	-------	--------

Delete Exit

Fig.8-2 System log

### 8.3 Statistic information

Statistic information includes instrument running time after startup and total instrument

running time, in system message menu of main screen, click “Statistic”, it will go to statistic information menu as below:

The screenshot shows a window titled "Statistic information" with a blue header. The main area is light beige and contains four rows of data, each with a label and a text box:

Running time since startup:	0 Hours 12 Minutes
Total running time:	0 Hours 12 Minutes
Tested samples today:	0
Total samples tested:	1

At the bottom of the window, there are two buttons: "Reset[R]" and "Exit[X]".

Fig.8-3 Statistic information

## 9 Shutdown

After work every day, you must run shutdown program before turning off instrument power. During shutdown, the instrument will perform routine maintenance and rinse test tubing. In main screen, click "Shut down" button, the system will pop up confirmation dialog box as below:

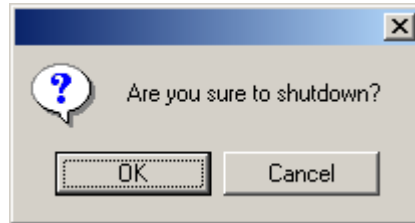

Fig.9-1 Shut down confirmation

Click "OK", the system runs shutdown program, after running, the instrument screen will display "Please power off" prompt, then instrument power can be switched off.

---

**Warning: never turn off power directly without running shutdown program.**

---

## 10 Service

Fully-automatic Hematology Analyzer is a clinical precision analyzer; in order to maintain good instrument condition, get reliable test result, and reduce instrument fault rate, the instrument shall be maintained routinely, this chapter introduces related maintenance operation.

---

**Warning: please perform maintenance operation according to user's manual and service manual, otherwise it may cause instrument damage.**

---

### 10.1 Routine maintenance

#### 10.1.1 Startup and shutdown process

At startup, the instrument will run mechanical component test and blank test, for user to discover problem as early as possible. While running shutdown operation, daily shutdown maintenance program will be automatically performed. After shutting off instrument power, just clean workbench and instrument surface.

#### 10.1.2 Automatic rinse

If number of samples instrument tests has reached the number preset by user, then the instrument will run automatic rinse program. User can adjust automatic rinse frequency at will. Refer to Chapter 7, System Setting. Rinse can also be done in "Maintenance" menu.

#### 10.1.3 Clean instrument surface

- Keep instrument working environment clean.
  - Instrument surface can be cleaned with neutral detergent and wet cloth.
- 

**Warning: do not use any solvent, fat, corrosive substance to clean instrument.**

---

### 10.2 Maintenance program

#### 10.2.1 Back flush

Back flush gem hole, together with the function of "Burn", to prevent and eliminate jam of hole.

#### 10.2.2 Burn

This function is to burn the gem hole to prevent and eliminate jam of hole.

#### 10.2.3 Drain chambers

Drain off the diluent in WBC and RBC chamber.

#### 10.2.4 Drain pipeline

Drain off liquid in the pipeline.

#### 10.2.5 Remove Blockage

Particular procedure to eliminate the blockage of hole.

### 10.2.6 Prime

System will prime automatically during sample test. If you have performed drain operation or replaced reagent, you shall perform the operation of priming.

- 1) All reagents: fill diluent, lyse and cleanser into related pipeline.
- 2) Diluent: fill diluent into related pipeline.
- 3) Lyse solution: fill lyse solution into related pipeline.
- 4) Cleanser: fill cleanser into related pipeline.

### 10.2.7 Cleaning

When you think that the chamber has been polluted or the blank test result keeps unacceptable, you shall use this function.

### 10.2.8 Concentrated cleanser soaking

Concentrated cleanser is an alkaliescent wash solution. It is used for cleaning pipeline and chamber. At the service menu, click "Bougie Fluid" to perform the concentrated cleanser soaking procedure. When the system give the message to add concentrated cleanser, add it manually into the chamber. You shall perform this operation once every three days.

### 10.2.9 Check mechanics

In Service menu, click "Check Mechanics" key, open mechanical test menu as below:

Mechanics	Result
Needle	
Carriage	
Liquid Syringe	
Pressure Syringe	
Valves	

Back

Fig.10-1 Mechanical test

Click "Needle", "Carriage", "Liquid Syringe", "Pressure Syringe", respectively, the instrument will test working condition of these components respectively; the results will be shown in corresponded boxes on the right.

While component is moving, carefully watch whether component movement is smooth and uniform, if there is still anomaly after repeated tests, please contact The manufacturer customer service department.

Click "Valve" button, open solenoid valve test screen as shown below:

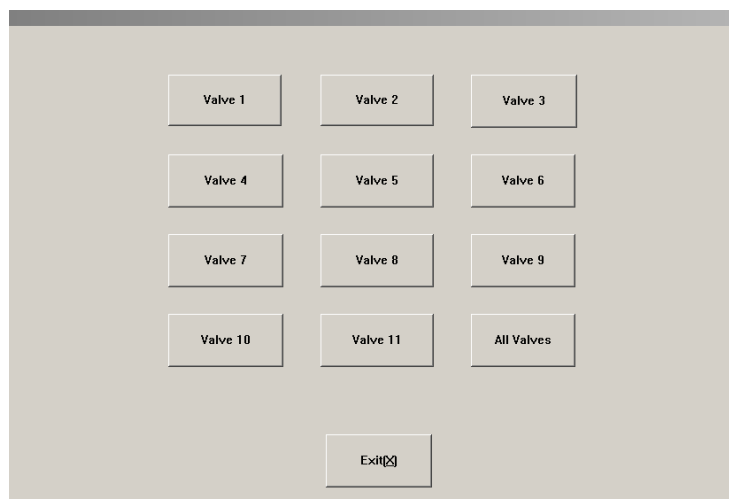

Fig.10-2 Solenoid valve test

The instrument has 11 solenoid valves totally, you can click corresponding button to test, or click “All solenoid valve” button to test all solenoid valves at the same time. If valves are normal, the movement shall be smooth and regular.

Click “Exit” button, return to mechanical test screen.

Function of each solenoid valve is as follows:

Solenoid valve 1: to control lyse solution dispensing.

Solenoid valve 2: to release positive pressure and negative pressure of pressure syringe.

Solenoid valve 3: to control WBC chamber cleanser adding during rinsing.

Solenoid valve 4: to drain pressure syringe.

Solenoid valve 5: to provide negative pressure needed by WBC and RBC chambers.

Solenoid valve 6: to control RBC chamber diluent adding during rinsing.

Solenoid valve 7: to control diluent and air aspiration in sampling needle flushing unit.

Solenoid valve 8: to control diluent in sampling needle unit.

Solenoid valve 9: to control diluent dispensing.

Solenoid valve 10: to control WBC chamber draining.

Solenoid valve 11: to control RBC chamber draining.

#### 10.2.10 Debug

For the engineer to test and debug the instrument.

#### 10.2.11 Engineering

This function sets up system parameters. These settings will have direct impact on test result, before modification, please confirm its necessity, normal users have no priority to modify, unless logging on with administrator account, see detail operation in “Chapter 7 System Setting”.

---

**Warning: engineers not trained by The manufacturer Company are refrained from using this function, otherwise test result accuracy will be affected, or even normal test can not be performed.**

---

#### 10.2.12 Machine reset

When mechanical component is out of step, you can restore original status with mechanical reset.

### **10.2.13 Stop use**

If the instrument will not be used for more than two weeks or to be packed for transportation, please conduct in following steps:

- a) In "Service" menu, select "Stop Use", complete operations according to the message given by system, when screen displays it's ready to shut down, shut off instrument power.
- b) For the remaining diluent, cleanser, Lyse, cover the bottles and turn tight, store as per reagent instruction.
- c) Power cables and adapters are to be cleaned with clean cloth dipped with neutral detergent, put in cool place, let dry, and pack in plastic bags.
- d) Put instrument and plastic bag packed components in instrument packing carton.

### **10.2.14 Replace reagent**

In order to make the system monitoring the using of reagent, when you are replacing the reagent, please input the volume of reagent you replaced in. System will record this volume and monitor the using of reagent, when the remaining volume is not enough, it will give a message.



## 11 Troubleshooting

This chapter describes common faults of instrument and their solutions, if failing to eliminate faults as per tips in this chapter or needing more detailed data, please contact the manufacturer customer service department.

Fault	Solution
1) Instrument cannot be started up	<ul style="list-style-type: none"> <li>—check if instrument is powered on</li> <li>—check if power plug gets loose or falls off</li> <li>—check voltage</li> </ul>
2) Instrument cuts power automatically	<ul style="list-style-type: none"> <li>—check instrument power is connected or not</li> <li>—check power cable is loose or not</li> <li>—power off instrument internal circuit breaker, and restart.</li> </ul>
3) No diluent	<ul style="list-style-type: none"> <li>—replace diluent, from main screen maintenance menu, select reagent filling -&gt; diluent</li> </ul>
4) No cleanser	<ul style="list-style-type: none"> <li>—replace cleanser, from main screen maintenance menu, select reagent filling -&gt; cleanser</li> </ul>
5) No Lyse	<ul style="list-style-type: none"> <li>—replace Lyse , from main screen maintenance menu, select reagent filling -&gt; lysis solution</li> </ul>
6) Waste bottle full	<ul style="list-style-type: none"> <li>—discard waste.</li> </ul>
7) Temperature abnormal	<ul style="list-style-type: none"> <li>—in software main menu, click “System Info” -&gt; “System Status”, check environment temperature, if not within 15°C~35°C range, restore instrument ambient temperature to this range</li> </ul>
8) Blank counting value higher repeatedly	<ul style="list-style-type: none"> <li>—reagent is used up or not</li> <li>—reagent is deteriorated or contaminated</li> <li>—calibrate instrument</li> <li>—check temperature or pressure if it is normal</li> </ul>
9) Parameter test incorrect	<ul style="list-style-type: none"> <li>—calibrate instrument</li> <li>—check if sampling needle location is right</li> <li>—check if there is bubble in fluid syringe, piston slides smoothly. If there is bubble, please make sure that reagent tubing connection is normal.</li> <li>—check solenoid valves if they work normally</li> </ul>
10) Printer cannot print	<ul style="list-style-type: none"> <li>—check printer if there is no paper</li> <li>—check if normally connected</li> <li>—check printer setting in system setting</li> </ul>
10) QC not in target range	<ul style="list-style-type: none"> <li>—check reagent validity period</li> <li>—check setting if it is right, and necessary to modify parameter.</li> <li>—make sure that QC process is not contaminated</li> <li>—test again in other method</li> </ul>

**Warning: only professional personnel verified by the manufacturer can repair this instrument.**

## Appendix Name and concentration of toxic and hazardous substance or element in product



Component name	Toxic / hazardous substance or element					
	Lead (Pb)	Mercury (Hg)	Cadmium (Cd)	Hexavalent chromium (Cr (VI))	Polybrominated biphenyls (PBB)	Polybrominated diphenyl ethers (PBDE)
Built-in PCB	×	○	○	○	○	○
Casing	×	○	○	○	○	○
Display screen	×	○	○	○	○	○
Optoelectric component	×	○	○	○	○	○
Internal wire	○	○	○	○	○	○
Ancillary part	×	○	○	○	○	○
<p>○: contents of this toxic/hazardous substance in all homogenous material of the component are below limit stated as per SJ/T11363-2006 standard.</p> <p>×: content of this toxic/hazardous substance at least in one homogenous material of the component is out of limit stated as per SJ/T11363-2006 standard.</p>						

**Note: for various versions of instrument, configuration may vary slightly, these variations are done without prejudice to instrument performance and use, please rest assured to use.**